



VC-40 | VC-60 | VC-90
VERTI-cutter

 **MADE IN USA**

Specializing in use on Golf Courses and Sports Fields

The First Products VERTI-cutter has dominated the golf and sports turf industry for years because of its durable construction, continuous reliability and fast operating speeds.



164 Oakridge Church Road | Tifton, GA 31794
1-229-382-4768 (or) 1-800-363-8780
www.1stproducts.com



QUALITY, PRECISION, DURABILITY

At 1st Products, our mission is to professionally market, sell, and distribute quality products and services, create exceptional customer satisfaction, and be the preferred supplier in our industry. In doing so, we will add value to our customers by offering innovative solutions, ensuring consistent product quality, and fostering long-term relationships built on trust and reliability.

VC-40

1st Products introduces a smaller, compact version of the same quality. The VC40 offers tighter blade spacing from and $\frac{1}{2}$ "-2" spacing and an optional thinner blade, makes it the best VERTI-cutter for compact tractors.



VC-60

The VERTI-cutter's patented swing-hitch allows the unit to turn during operation increasing maneuverability and the belt drive with 12" diameter blades provides a faster blade RPM (tip speed) improving quality of cut.



VC-90

Building on our commitment to quality and durability, the VC-90 features an all-welded steel construction and 12" diameter blades, designed for those demanding maximum efficiency and longevity. Ideal for larger tractors, the VC-90 combines size and strength, offering professional-grade cutting for expansive turf areas.



SPECIFICATIONS

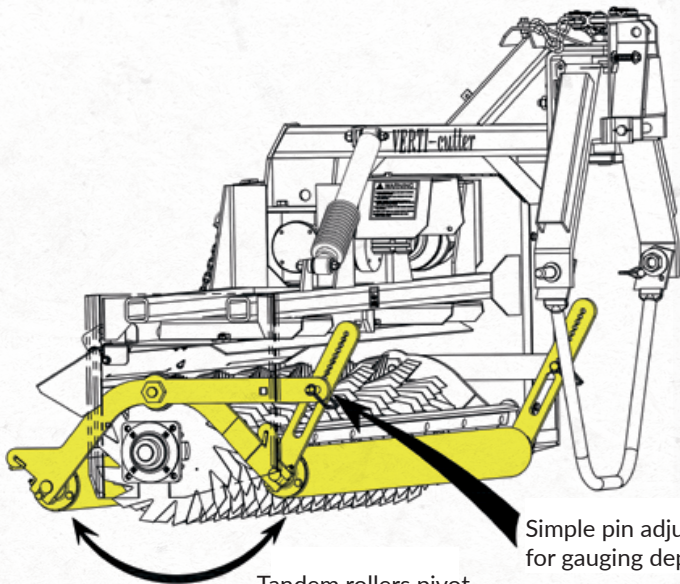

Tandem rollers pivot around blades for consistent cutting depth

Simple pin adjustment for gauging depth

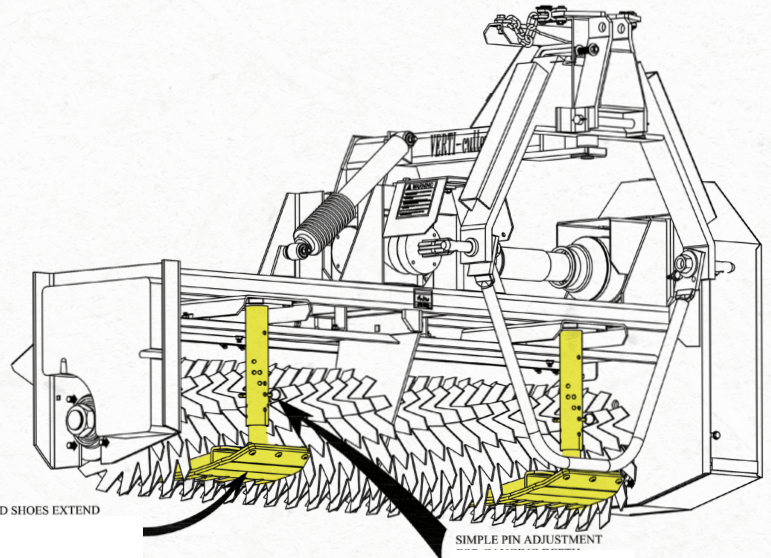

SKID SHOES EXTEND

Skid shoes extend between blades for consistent cutting depth over uneven turf

SIMPLE PIN ADJUSTMENT

Simple pin adjustment for gauging depth

	VC-40	VC-60	VC-90
Working Width	35 1/2"	54"	84"
Blades	10 Ga Carbide Tip 16 Ga Carbide Tip 10 Ga Hardened Steel	10 Ga Carbide Tip 10 Ga Hardened Steel	10 Ga Carbide Tip 10 Ga Hardened Steel
Blade Spacing	Rollers 1/2" - 2" (1/4" Increments)	Rollers 1.5 - 2 / Skids 2" Only	2"
Blade Depth Control	0 - 1 7/8"	0 - 1 7/8"	0 - 1 7/8"
Blade Shaft	1 5/8" Hex Stress Proof	1 5 / 8" Hex Stress Proof	1 5 / 8" Hex Stress Proof
Blade Rotation	Forward	Forward	Forward
Hitch	Patented 3 Pt Cat.1 Trailing Hitch	Patented 3 Pt. Cat. 1 Trailing Hitch	Patented 3 Pt. Cat. 1 Trailing Hitch
Drive	540 PTO Gearbox, 3 Belts	540 PTO Gearbox, 5 Belts	540 PTO Gearbox, 12 Belts
Required Hp	20 - 45 HP Varies By Cutting Depth	25 - 45 HP Varies By Cutting Depth	30 - 55 HP Varies By Cutting Depth
Frame	All Welded Steel Construction	All Welded Steel Construction	All Welded Steel Construction
Weight	800 Lbs.	900 Lbs.	1250 Lbs.
Dimensions	51" W, 24" L, 44" H	70" W, 46" L, 41" H	96" W, 72" L, 42" H
Gearbox	Heavy Duty 42 HP (31 Kw)	Heavy Duty 42 HP (31 Kw)	Heavy Duty 55 HP (31 Kw) Right Angle 30 HP

VC-40

VERTI-cutter



First Products introduces a smaller, compact version of the same quality. The VC40 offers tighter blade spacing from and ½"-2" spacing and an optional thinner blade, makes it the best VERTI-cutter for compact tractors.

Double Rollers

The double roller depth gauge system allows consistent depth control over undulations.

Available for VC-40 and VC-60



VC-60

VERTI-cutter



Double Rollers

The double roller depth gauge system allows consistent depth control over undulations.

1 1/2" spacing available now

Available for VC-40 and VC-60

Skids

The depth gauge skids are directly centered under the shaft allowing the skids to float over level surfaces. 2" spacing only.

Not available for VC-40



VC-90 VERTI-cutter



Improve your turf's health with the VC-90 VERTI-cutter. Designed for precision, the VC-90 effectively manages thatch and soil compaction, enhancing air, water, and nutrient absorption. Ideal for professionals, it ensures resilient, thriving grass with minimal effort.

- 3 Independent Floating Heads
- Front Roller for Smoother Cut
- Hinged Rear Shield
- Fast Depth Adjustment
- Open Discharge
- Patented Swing Hitch

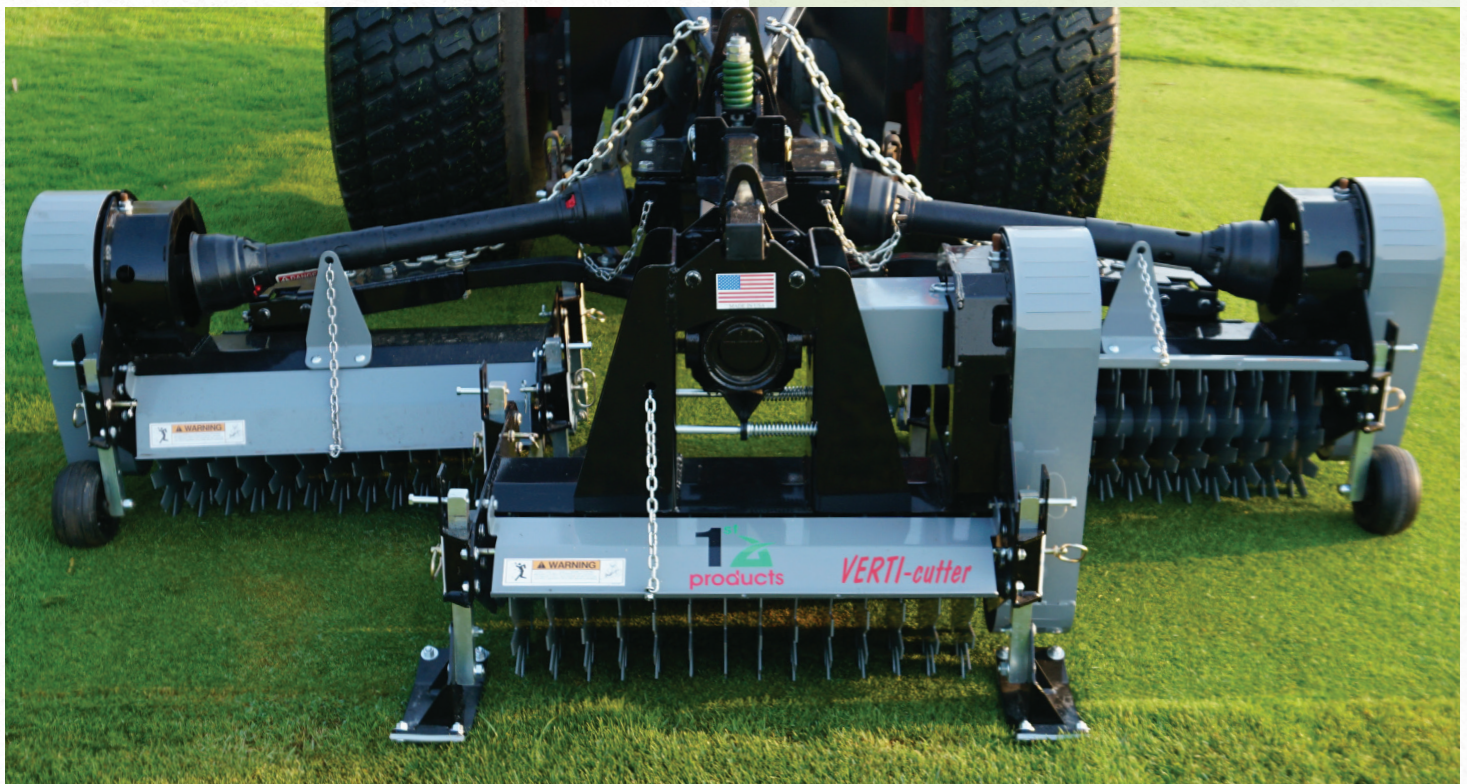



“At Aeration Technology, verti-cutting is one of the many contracting services we proudly offer across the state of Florida. Each year, we verticut 5,000 acres of fairways, and in that time, we’ve tested nearly every verticutter on the market. Without a doubt, nothing compares to the performance and durability of 1st Products equipment. We currently operate over 12 VC-60s for fairways and tees, along with a few VC-40s for greens, and we’ve recently added our first VC-90 to the fleet. We are extremely impressed—the VC-90 is a tank! It delivers unmatched power, efficiency, and reliability. On top of that, the customer service from 1st Products is second to none. In an era when top-notch service is rare, they consistently go above and beyond to ensure our needs are met. We highly recommend 1st Products for their exceptional equipment and outstanding customer support!”

MICHEAL SHEA

Owner Operator | Aeration Technology | Naples/ Fort Lauderdale, Florida



See the VERTI-cutter in action!

Scan the QR code to explore our YouTube video library.



164 Oakridge Church Road | Tifton, GA 31794

1-229-382-4768 (or) 1-800-363-8780

www.1stproducts.com



First Products, Inc. has a company policy of continuous improvements and development; therefore specifications are subject to change without notice. The company accepts no responsibility for discrepancies in specifications contained in this publication.

Patent No(s): 7,428,874; 8,640,784; 7,677,324